

● CUSTOMIZATION ECR SERIES

ECR serie electromagnets are linear reversible solenoids, where the stroke is made by the alternative piloting of two coils, each one must be excited alternatively to make the movement as shown in the figure 1. To keep any final stroke position, the coil must remain under voltage.

These solenoids are used in those applications where force must be the same for both movement senses push and pull.

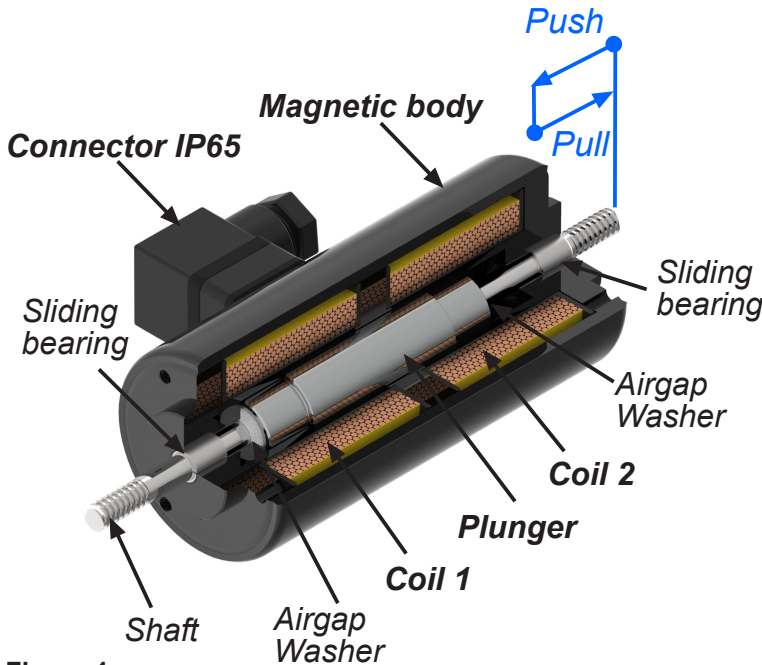

Figure 1.

Structure, basic components

Magnetic body:

The metallic piece containing the coils, and the plunger of the solenoid.

Coils:

They are those that receive the electrical energy to create the magnetic field. The plunger moves towards the coil that is excited.

Plunger:

It moves inside along the coil, and it has a non-magnetic shaft fixed to it. The shaft has got two screwed sides so that they can be used both to push and pull.

Connector (DIN43650):

It is the part where the electrical connection takes place. It has got a stuffing box PG11. For more info see page 73.

● Datasheet rated values conditions (According to DIN VDE 0580):

The values of the magnetic force (F_m) depending on the stroke, are obtained in the following conditions:
 Room temperature = 35°C
 Coil stabilized at its working temperature.
 Rated voltage equal to 90% of the standard one.
 Solenoid working in horizontal position.

The effective force (F_h) is obtained from magnetic force (F_m) adding or subtracting the weight of the plunger.

1) When the solenoid pushes or pulls upwards or downwards:

$Effective\ force = Magnetic\ force \pm plunger\ weight$

2) When the solenoid pushes or pulls in horizontal position:

$Effective\ force = Magnetic\ force$

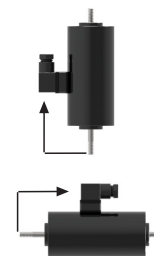

REMARK: The work option 2) increases the abrasion of the slide bearings comparing to mounting option 1).

● 4x90° adjustable connector by the user :



● CUSTOMIZATION ECR SERIES

<p>Figure 4. Connector base mounted on the solenoid, must not be manipulated</p>	<p>1) The electrical connection will be detailed in the following points.</p> <p>Figure 5.</p>
<p>3) Take off the connector pulling it up.</p> <p>Figure 7.</p>	<p>2) Take out the screw between the connector and the base.</p> <p>Figure 6.</p>
<p>3) Take off the connector pulling it up.</p> <p>Figure 7.</p>	<p>4) Take off the rubber piece.</p> <p>Figure 8.</p>
<p>5) Remove the interior piece, this one has power terminals. To remove it, push the carrier between the terminals 1 and the mass one. Finally take off the stuffing box and connect the supply cables like in figure 11.</p> <p>Figure 9.</p> <p>Figure 10. Stuffing box</p>	
<p>Figure 11.</p>	<p>Connection by the user</p> <p>Take out the screws, take in the supply cables in the power terminals and screw them again</p>
<p>Figure 12.</p>	<p>Coil 1 under voltage</p> <p>Figure 13.</p> <p>Coil 2 under voltage</p> <p>Figure 14.</p> <p>Connection between base connector and coil, realized by the manufacturer</p>

• ECR series: Force-stroke Chart

Type	Stroke (mm)		Duty-cycle				
			100%	40%	25%	15%	5%
ECR40-07	Beginning of stroke $s_1=07$	Magnetic force "Fm" (N)	10	17.9	22	28	46
	End of stroke $s_0=0$		10.4	16	19.6	27	43
ECR50-16	Beginning of stroke $s_1=16$		18.7	30	41	56	92
	End of stroke $s_0=0$		44	84	104	133	193
ECR65-15	Beginning of stroke $s_1=15$		46	73	91	118	177
	End of stroke $s_0=0$		152	199	253	303	385
ECR72-30	Beginning of stroke $s_1=30$		28	42	56	71	146
	End of stroke $s_0=0$		68	112	148	182	269
ECR90-25	Beginning of stroke $s_1=25$		85	126	163	205	341
	End of stroke $s_0=0$		265	379	501	578	837

The values of force-stroke and the return spring are in Newton (N), solenoid in horizontal position and without return spring.

● CUSTOMIZATION ECR SERIES

The models described in the catalogue are standard and minimum manufacturing batches are not required. However, there is the possibility of customizing them to suit better customer's needs. See below some of the most common customizations. If any modification is needed, please ask NAFSA about the possibility and the minimum manufacturing batch required.

1. ELECTRICAL CUSTOMIZATION

a) DIN43650A connectors replacement by supply cables



Example 1:
ECR90-25/CC

b) Intermediate duty-cycle manufacturing:

NAFSA can manufacture any intermediate duty-cycle from 0 to 100, but the viability depends on the model and the voltage associated with it. For any special requirement, please ask NAFSA.

c) Different duty-cycle manufacturing for each coil:

ECR serie electromagnets are linear reversible solenoids, where the stroke is made by the alternative piloting of two coils. In case of different forces need for each stroke direction, there is the option of manufacture each coil with different duty-cycle. For any special requirement, please ask NAFSA.

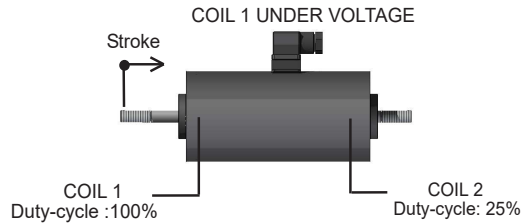

Example 2:
ECR90-25.01R.24.100-25.C

2. INSULATION CLASS CUSTOMIZATION:

Depending on the model, insulation class can be increased until H (180°C), this change is limited to voltages less than 48VDC, this usually involves DIN43650A connectors replacement by cables or another type of connectors. For any special requirement, please ask NAFSA.

3. PROTECTION RATE CUSTOMIZATION IP (EN60529):

Standard models are IP40, but protecting the shaft and its guides IP54 can be obtained.



Example 3:
Bellows have been added in the shaft

4. MECHANICAL CUSTOMIZATION

a) Shaft modifications:



Example 4:
Shaft diameter, length, thread can be modified

b) Stroke modifications:



Example 5:
ECR40-16/RO
Modification of ECR40-07 stroke has been increased from 7mm to 16mm

c) Fastening element added as Fork joint DIN71752



Example 6:
ECR50-16+Fork joint
Modification ECR50-16, DIN71752 fork joint has been added

• ECR 40-07 TYPE



Protection rate: **IP40**
 Insulation class: **B (130°C)**
 Reference cycle: **5 minutes**
 Standard stroke (s): **7 mm**
 Temperature rise "ΔV₃₁": **70°C**
 Working temperature: **-10 to 45°C**
 Work: **Push / Pull**

Release spring NOT
 incorporated in standard
 product.

(ED) Duty-cycle ED(%)	100	40	25	15	5
(P20) Power at 20°C (W)	13	30	45	75	210
(Fm) Solenoid force (N) 1)	10	15	18	22	37
Max time under voltage(s)	Inf	120	75	45	15
Opening time (ms) 2)	117	95	84	79	77
Release time (ms) 3)	70	57	51	48	46
Plunger weight (Kg)	0.140				
Solenoid weight (Kg)	0.8				

1) Fm Solenoid force is given according to VDE0580 without deducting the spring force or the plunger weight if vertical mounting.

2) Time is given on these conditions: Coil supplied under nominal voltage ; Stabilized in it's working temperature ; Load 70% of the solenoid force ; Horizontal assembly ; Standard stroke initial position; 20°C ambient temperature.

3) Time is given on these conditions: without load on shaft ; Horizontal assembly ; Standard stroke initial position.

Duty-cycle ED%	Standard voltages								Under demand				
	VDC							VAC		VDC		VAC	
	6	12	24	48	100	125	205	110	230	Min	Max	Min	Max
100	o	o	o	o	o	o	o	x	x	5	250	x	x
40	o	o	o	o	o	o	o	x	x	6	250	x	x
25	x	o	o	o	o	o	o	x	x	9	250	x	x
15	x	o	o	o	o	o	o	x	x	9	250	x	x
5	x	o	o	o	o	o	o	x	x	12	250	x	x

Layout: o = Available ; x = Unavailable

- Voltage under demand:
 They can be manufactured at voltages between the maximum and minimum voltage values shown in the chart.

- To feed in alternating current, there has to be an external rectification of the signal.

- The duty cycles described in the chart are standard, they can be manufactured in any intermediate value.

- If any customization from the original is needed, please ask us.

- Earthing is recommended if the metallic parts are accessible.

Ordering code: ECR40-07 --V ED---%
 Voltage: 24Vdc; Duty cycle: ED100%; ECR40-07 24Vdc ED100%
 Voltage: 12Vdc; Duty cycle: ED15%; ECR40-07 12Vdc ED15%

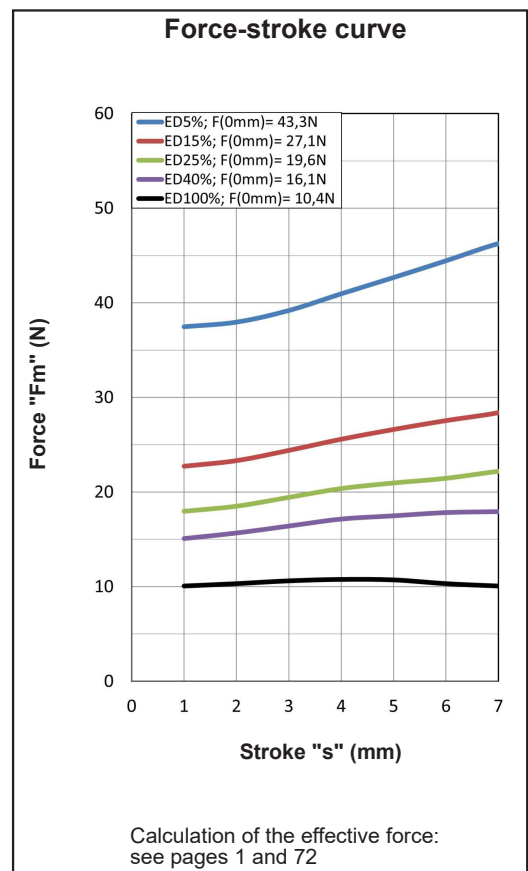
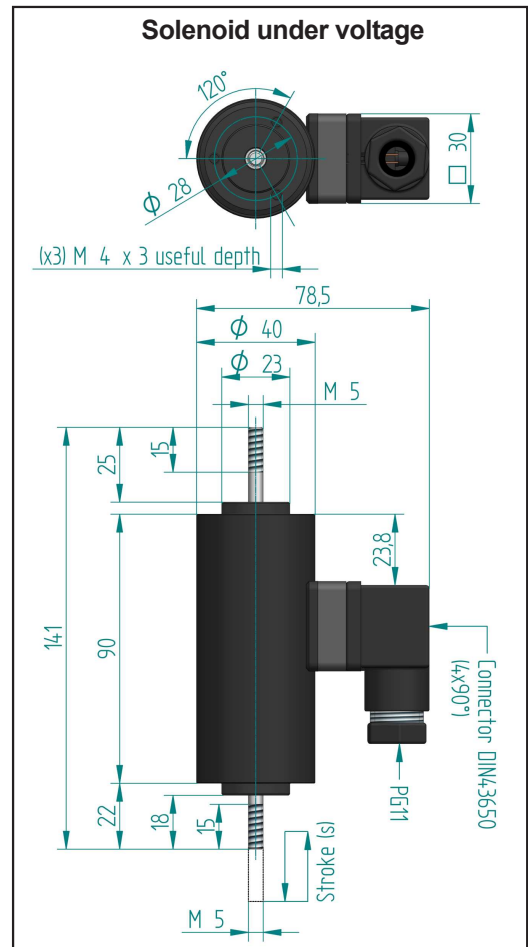

For fixation of the solenoid: see page 72

● **ECR 50-16 TYPE**



Protection rate: **IP40**
 Insulation class: **B (130°C)**
 Reference cycle: **5 minutes**
 Standard stroke (s): **16 mm**
 Temperature rise "ΔV₃₁": **70°C**
 Working temperature: **-10 to 45°C**
 Work: **Push / Pull**

Release spring NOT
 incorporated in standard
 product.

(ED) Duty-cycle ED(%)	100	40	25	15	5
(P20) Power at 20°C (W)	20	45	70	120	320
(Fm) Solenoid force (N) 1)	13	18	26	41	72
Max time under voltage(s)	Inf	120	75	45	15
Opening time (ms) 2)	203	160	137	127	116
Release time (ms) 3)	131	106	92	86	80
Plunger weight (Kg)	0.220				
Solenoid weight (Kg)	1.4				

1) Fm Solenoid force is given according to VDE0580 without deducting the spring force or the plunger weight if vertical mounting.

2) Time is given on these conditions: Coil supplied under nominal voltage ; Stabilized in it's working temperature ; Load 70% of the solenoid force ; Horizontal assembly ; Standard stroke initial position; 20°C ambient temperature.

3) Time is given on these conditions: without load on shaft ; Horizontal assembly ; Standard stroke initial position.

Duty-cycle ED%	Standard voltages								Under demand				
	VDC							VAC		VDC		VAC	
	6	12	24	48	100	125	205	110	230	Min	Max	Min	Max
100	o	o	o	o	o	o	o	x	x	5	250	x	x
40	x	o	o	o	o	o	o	x	x	9	250	x	x
25	x	o	o	o	o	o	o	x	x	9	250	x	x
15	x	o	o	o	o	o	o	x	x	12	250	x	x
5	x	x	o	o	o	o	o	x	x	24	250	x	x

Layout: o = Available ; x = Unavailable

- Voltage under demand:
 They can be manufactured at voltages between the maximum and minimum voltage values shown in the chart.

- To feed in alternating current, there has to be an external rectification of the signal.

- The duty cycles described in the chart are standard, they can be manufactured in any intermediate value.

- If any customization from the original is needed, please ask us.

- Earthing is recommended if the metallic parts are accessible.

Ordering code: ECR50-16 --V ED---%
 Voltage: 24Vdc; Duty cycle: ED100%; ECR50-16 24Vdc ED100%
 Voltage: 12Vdc; Duty cycle: ED15%; ECR50-16 12Vdc ED15%

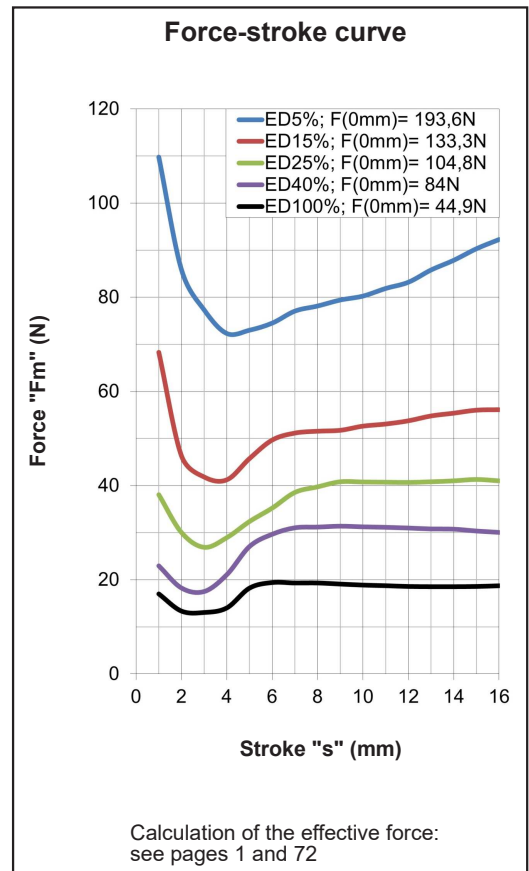
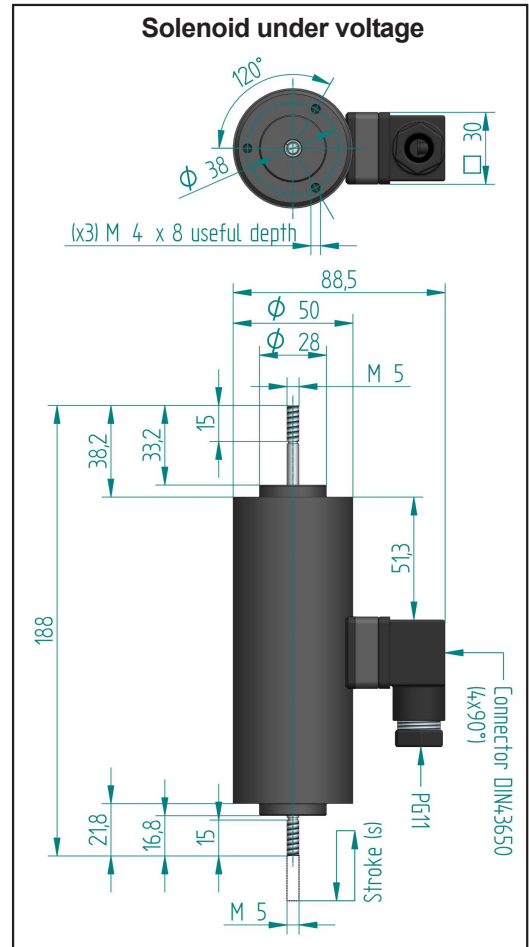

For fixation of the solenoid: see page 72

• ECR 65-15 TYPE



Protection rate: **IP40**
 Insulation class: **B (130°C)**
 Reference cycle: **5 minutes**
 Standard stroke (s): **15 mm**
 Temperature rise "ΔV₃₁": **70°C**
 Working temperature: **-10 to 45°C**
 Work: **Push / Pull**

Release spring NOT
 incorporated in standard
 product.

(ED) Duty-cycle ED(%)	100	40	25	15	5
(P20) Power at 20°C (W)	30	75	110	185	545
(Fm) Solenoid force (N) 1)	38	64	80	99	162
Max time under voltage(s)	Inf	120	75	45	15
Opening time (ms) 2)	291	228	198	196	181
Release time (ms) 3)	181	143	125	124	115
Plunger weight (Kg)	0.350				
Solenoid weight (Kg)	2.8				

1) Fm Solenoid force is given according to VDE0580 without deducting the spring force or the plunger weight if vertical mounting.

2) Time is given on these conditions: Coil supplied under nominal voltage ; Stabilized in it's working temperature ; Load 70% of the solenoid force ; Horizontal assembly ; Standard stroke initial position; 20°C ambient temperature.

3) Time is given on these conditions: without load on shaft ; Horizontal assembly ; Standard stroke initial position.

Duty-cycle ED%	Standard voltages								Under demand				
	VDC							VAC		VDC		VAC	
	6	12	24	48	100	125	205	110	230	Min	Max	Min	Max
100	x	o	o	o	o	o	o	x	x	9	250	x	x
40	x	o	o	o	o	o	o	x	x	12	250	x	x
25	x	x	o	o	o	o	o	x	x	24	250	x	x
15	x	x	o	o	o	o	o	x	x	24	250	x	x
5	x	x	o	o	o	o	o	x	x	24	250	x	x

Layout: o = Available ; x = Unavailable

- Voltage under demand:
 They can be manufactured at voltages between the maximum and minimum voltage values shown in the chart.

- To feed in alternating current, there has to be an external rectification of the signal.

- The duty cycles described in the chart are standard, they can be manufactured in any intermediate value.

- If any customization from the original is needed, please ask us.

- Earthing is recommended if the metallic parts are accessible.

Ordering code: ECR65-15 --V ED---%
 Voltage: 24Vdc; Duty cycle: ED100%; ECR65-15 24Vdc ED100%
 Voltage: 48Vdc; Duty cycle: ED15%; ECR65-15 48Vdc ED15%

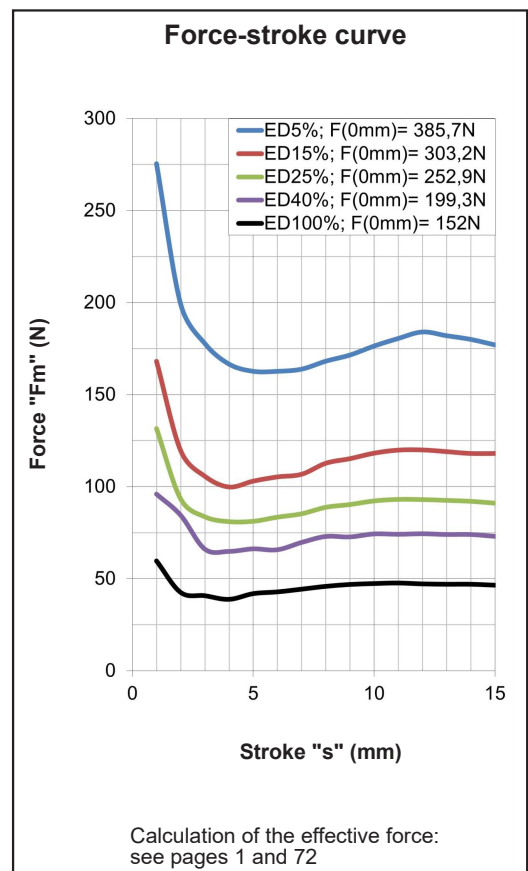
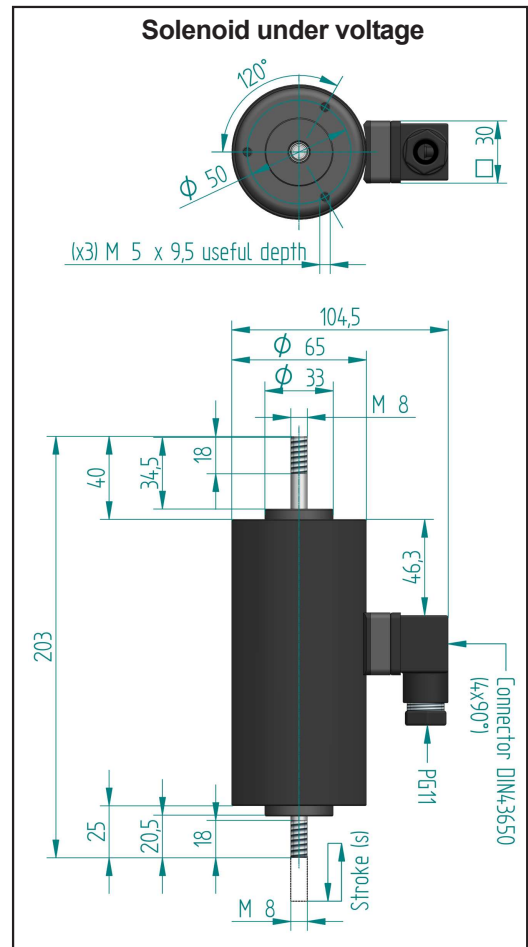

For fixation of the solenoid: see page 72

● ECR 72-30 TYPE



Protection rate: **IP40**
 Insulation class: **B (130°C)**
 Reference cycle: **5 minutes**
 Standard stroke (s): **30 mm**
 Temperature rise " ΔV_{31} ": **70°C**
 Working temperature: **-10 to 45°C**
 Work: **Push / Pull**

Release spring NOT incorporated in standard product.

(ED) Duty-cycle ED(%)	100	40	25	15	5
(P20) Power at 20°C (W)	34	98	166	195	830
(Fm) Solenoid force (N) 1)	28	42	56	71	146
Max time under voltage(s)	Inf	120	75	45	15
Opening time (ms) 2)	410	352	284	269	241
Release time (ms) 3)	256	222	181	172	156
Plunger weight (Kg)	0.400				
Solenoid weight (Kg)	3.2				

1) Fm Solenoid force is given according to VDE0580 without deducting the spring force or the plunger weight if vertical mounting.

2) Time is given on these conditions: Coil supplied under nominal voltage ; Stabilized in it's working temperature ; Load 70% of the solenoid force ; Horizontal assembly ; Standard stroke initial position; 20°C ambient temperature.

3) Time is given on these conditions: without load on shaft ; Horizontal assembly ; Standard stroke initial position.

Duty-cycle ED%	Standard voltages								Under demand				
	VDC							VAC		VDC		VAC	
	6	12	24	48	100	125	205	110	230	Min	Max	Min	Max
100	o	o	o	o	o	o	o	x	x	5	250	x	x
40	x	o	o	o	o	o	o	x	x	9	250	x	x
25	x	o	o	o	o	o	o	x	x	12	250	x	x
15	x	o	o	o	o	o	o	x	x	12	250	x	x
5	x	x	o	o	o	o	o	x	x	24	250	x	x

Layout: o = Available ; x = Unavailable

- Voltage under demand:
They can be manufactured at voltages between the maximum and minimum voltage values shown in the chart.

- To feed in alternating current, there has to be an external rectification of the signal.

- The duty cycles described in the chart are standard, they can be manufactured in any intermediate value.

- If any customization from the original is needed, please ask us.

- Earthing is recommended if the metallic parts are accessible.

Ordering code: ECR72-30 --V ED---%

Voltage: 24Vdc; Duty cycle: ED100%; ECR72-30 24Vdc ED100%

Voltage: 12Vdc; Duty cycle: ED15%; ECR72-30 12Vdc ED15%

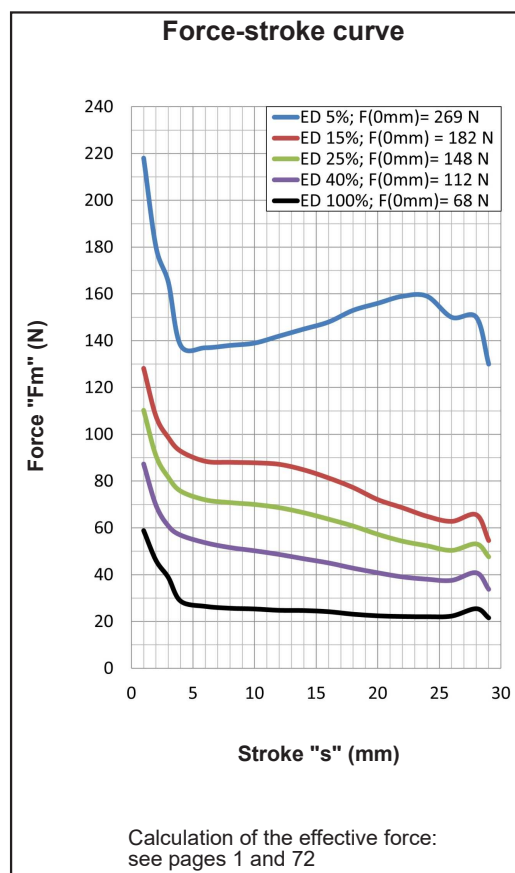
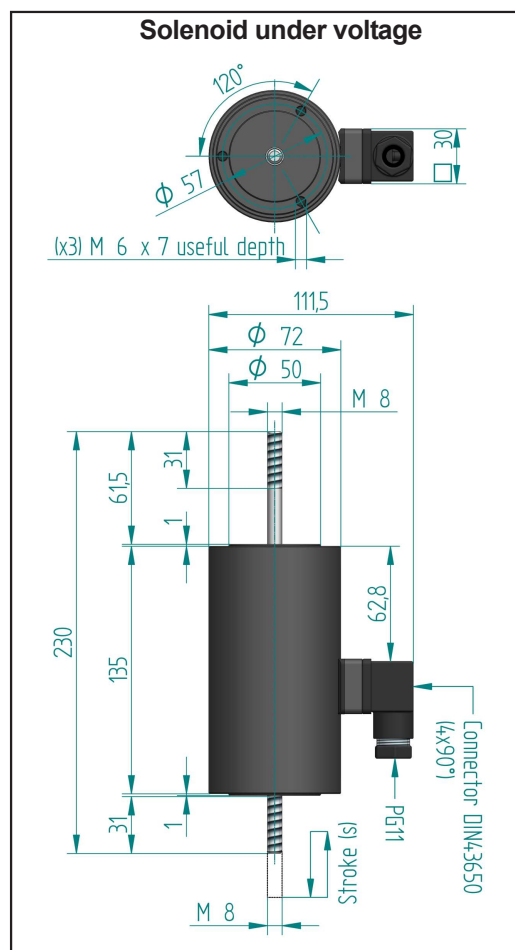

For fixation of the solenoid: see page 72

• ECR 90-25 TYPE



Protection rate: **IP40**
 Insulation class: **B (130°C)**
 Reference cycle: **5 minutes**
 Standard stroke (s): **25 mm**
 Temperature rise " ΔV_{31} ": **70°C**
 Working temperature: **-10 to 45°C**
 Work: **Push / Pull**

Release spring NOT
 incorporated in standard
 product.

(ED) Duty-cycle ED(%)	100	40	25	15	5
(P20) Power at 20°C (W)	55	125	190	300	900
(Fm) Solenoid force (N) 1)	70	111	146	178	305
Max time under voltage(s)	Inf	120	75	45	15
Opening time (ms) 2)	651	488	417	332	307
Release time (ms) 3)	399	301	259	208	193
Plunger weight (Kg)	0.900				
Solenoid weight (Kg)	8.5				

1) Fm Solenoid force is given according to VDE0580 without deducting the spring force or the plunger weight if vertical mounting.

2) Time is given on these conditions: Coil supplied under nominal voltage ; Stabilized in it's working temperature ; Load 70% of the solenoid force ; Horizontal assembly ; Standard stroke initial position; 20°C ambient temperature.

3) Time is given on these conditions: without load on shaft ; Horizontal assembly ; Standard stroke initial position.

Duty-cycle ED%	Standard voltages								Under demand				
	VDC						VAC		VDC		VAC		
	6	12	24	48	100	125	205	110	230	Min	Max	Min	Max
100	x	o	o	o	o	o	o	x	x	12	250	x	x
40	x	x	o	o	o	o	o	x	x	24	250	x	x
25	x	x	o	o	o	o	o	x	x	24	250	x	x
15	x	x	o	o	o	o	o	x	x	24	250	x	x
5	x	x	o	o	o	o	o	x	x	24	250	x	x

Layout: o = Available ; x = Unavailable

- Voltage under demand:
They can be manufactured at voltages between the maximum and minimum voltage values shown in the chart.

- To feed in alternating current, there has to be an external rectification of the signal.

- The duty cycles described in the chart are standard, they can be manufactured in any intermediate value.

- If any customization from the original is needed, please ask us.

- Earthing is recommended if the metallic parts are accessible.

Ordering code: ECR90-25 --V ED---%

Voltage: 24Vdc; Duty cycle: ED100%; ECR90-25 24Vdc ED100%

Voltage: 48Vdc; Duty cycle: ED15%; ECR90-25 48Vdc ED15%

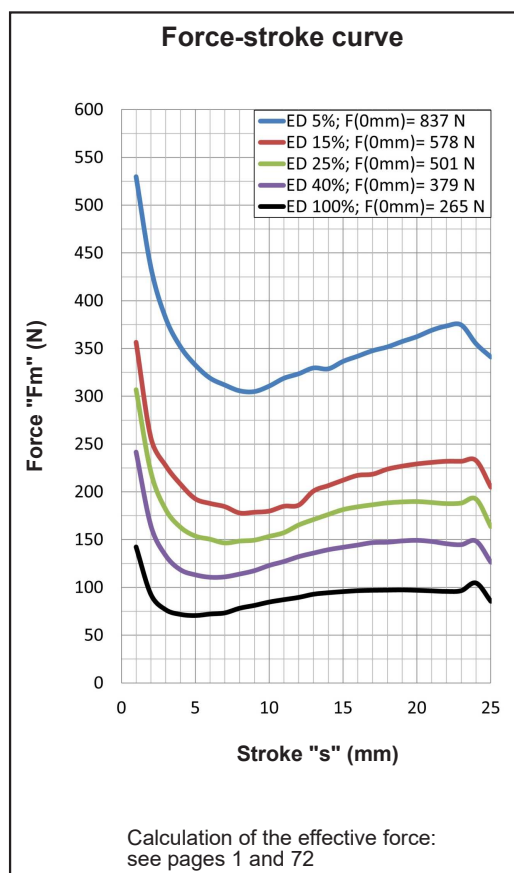
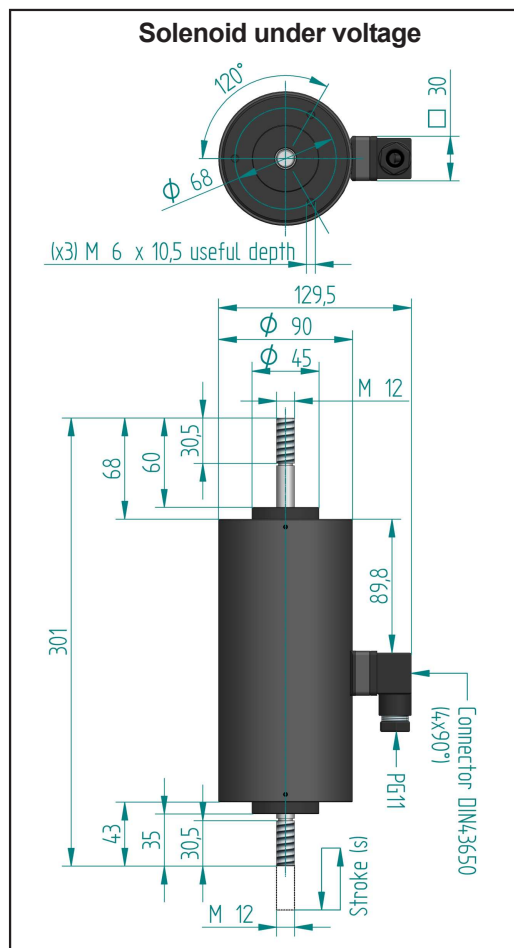

For fixation of the solenoid: see page 72